

SOYAL

RFID CONTROLLER BUILD IN READER MANUAL

AR-721HV3
AR-721HV3-1356



2005/06/01

Table of Contents

	Page
1 Introduction	2
2 Features	2
3 Specification	3
4 Installation Notice	4
5 Front Panel Indicators	7
6 Access Mode	8
User can select one of the following access modes	8
AR-721HV3/1356	8
Duress function	9
Force on/off Code (4 sets, 4 digits)	9
7 Function Default Value	11
8 Wiring	12
9 Installation Diagram	13
10 Installation	24
11 Troubleshooting	24
12 Return of Products	24
13 Warranty	25
Removable CPU	25
14 Mode 4 Easy Guide	26
15 Mode 8 Easy Guide	30
16 Mode 6 Easy Guide	31
17 Mode 7 Easy Guide	33
18 Special Design	35
19 Transponder Record Table	38
19.1 For AR-721H4, AR-721H7 and AR-721H8	38
19.2 For AR-721H6	39
20 FAQ	40

1. INTRODUCTION

Getting to know your SOYAL Proximity Reader....

The *AR-721HV3* & *AR-721HV1356* are smart single door controller. It built-in a 6" RF reader and an external reader port for exit or anti-pass-back use. It can work standalone including 1000 cardholders with anti-pass-back function. Or connect with multi-door networking controller to provide 15,000 cardholders with multi door anti-pass-back access control. About networking of AR-721H series. Once the network communication stop over 10 seconds on the RS-485 port. It will auto enter standalone control mode .

Notice:

The reader of AR-721HV2 owns the same functions as AR-721HV3 except for Calendar & Time system supporting and 1,200 Transaction Buffer features.

Copyright © 2004 Soyal Technology Co. Ltd.
All Rights Reserved.

2. Features

- Calendar & Time system supporting.
- Providing proximity card flash edit mode for easy & quick setting.
- Two Sets of Auto-Open Zone Function.
- Built-in opened door relay, alarm relay and request to exit button input.
- Up to 1,200 Transaction Buffer.
- Master Card Range assignable.
- Run as a standalone controller during failure.
- Support Auto-relock Function.
- Universal serial port supported for LED display, printer, Lift controller, etc.
- Intergrades any brand, any frequency of Wiegand reader with soyal or other access control systems.
- Keypad will be locked for 30 seconds while continuous error operation.
- Press [*] + [#] to lock / unlock keypad immediately.
- Built-in watchdog to prevent the system from halting.
- Door unlock time setting, latched-on/latched-off or momentary 0.1-600 seconds.
- Alarm function is available (temper, force entrance, door open too long, duress).
- 12 numeric keypad, 1 bicolor LED (green and red) and buzzer indicator.



3. Specification

Mode Description:

MODE	M4	M6	M8
Card Holder	1024	65536	1024
Card Code	32 bits	16 bits	32 bits
Lift Control	32	*	32
Anti-Pass-back	1024	*	1024
Connect to 716EV2	Y	*	Y
PC	Y	*	Y
Access Mode	A	B	C
Transaction Buffer	1200	*	1200

Access Mode A: Card only, Card + PIN, PIN + Code

Access Mode B: Card only, PWD only, Card + PWD

Access Mode C: Card Only, Card + PIN, PIN only

How to get the Mode Status

Step 1. Press

+ + enter the FUNCTION MENU

Step 2. You will hear the “Beep” sound from the machine , as follows:

M4: Sound with 4 times

M6: Sound with 6 times

M8: Sound with 8 times

How to change the Mode Status

Step 1. Press

+ + enter the FUNCTION MENU

Step 2. Editing Mode

M4:press *and hearing*
Beep Sound with 4 times

M6: press *and hearing*
Beep Sound with 6 times

M8: press *and hearing*
Beep Sound with 8 times

4. Installation Notice

Drawing 1

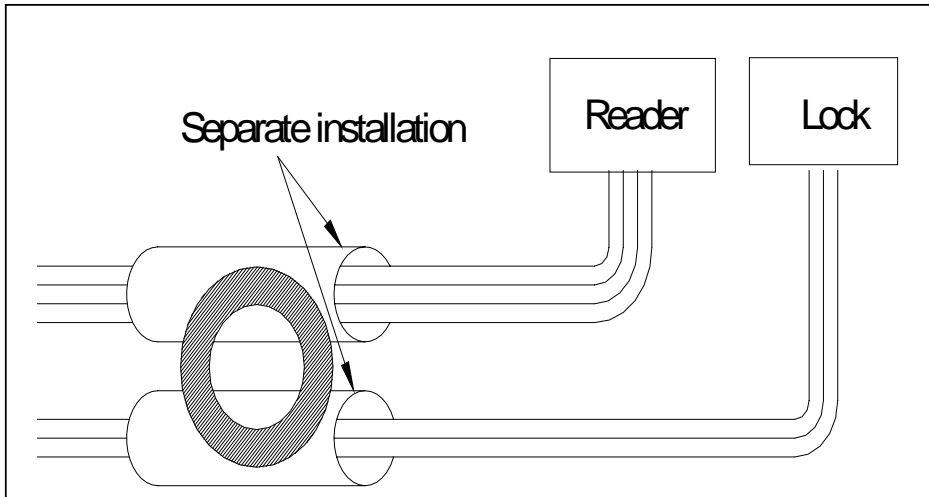

Drawing 2

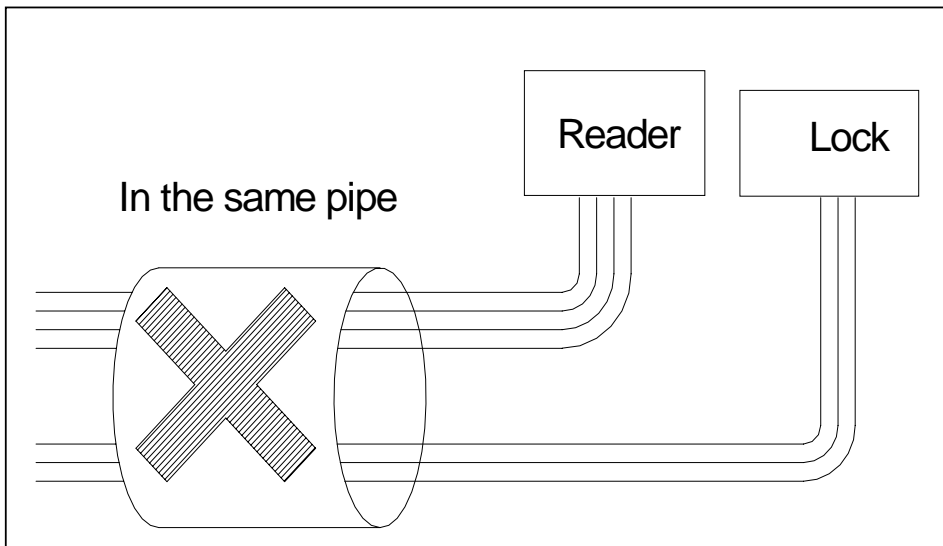

AR-721HV3 / 1356

- 1** RS-232: The distance between PC and converter (AR-801CM) can not be more than 2 meters
- 2** RS-485: The distance between converter (AR-801CM) and the farthest controller (or reader) can not be more than 300 meters.
- 3** Wiegand: The distance between RS-485 reader (or controller) and Wiegand reader can not be more than within 3 to 5 meters.
- 4** Do not run AC power in the same pipe with communication wire(See drawing 2). It should be separate installation (See drawing 1).
- 5** AR-721H locate inside the secure area for use as an exit controller, the auxiliary reader locate exterior wall for use as an entrance reader, but not directly behind AR-721H. For best reading distance, offset the AR-721H and auxiliary reader by about 50 cm above and 12 m below (suggestion value).
- 6** Normally, AR-721H will read a Card / Key Tag at up to 15 cm. However, when AR-721H or optional auxiliary reader is mounted directly on a metal surface, the reading distance decreases slightly. To reduce this effect, install wood or plastic between the mounting surface and mounting plate, this will restore most of the reading distance.

AR-721HV3 / 1356

- 7** Exit Switch input must be a dry contact, with no voltage present.
- 8** AR-721H can cover standard electrical boxes.
- 9** AR-721H does not supply power to operate electric strike or magnetic locks – a separate supply is required. Refer to strike/magnetic lock manufactures instructions. If common power supply is used for both the AR-721H and electronic door lock, be sure to install the diode which is provided with the AR-721H.
- 10** Alternatively, you can use any good 9-18 VDC supply that provides at least 150mA. DC power should be clean and filtered with no more than 1 VAC ripple (Peak to Peak). Do not run AC power in the same cable with DC power to the AR-721H. While it is always preferable to use a separate power supply for the AR-721H and strike.
- 11** Run the following cables to the AR-721H location. Conduit is recommended to reduce the effects of EMI/RFI and for physical protection of the wires.

We suggest that the customer use "Shield Twisted Pair" and avoid Star wiring for good communication when installation.

a. We suggest using the following cable in RS-485 communication.

b. Please use the following installation method, it is correct.

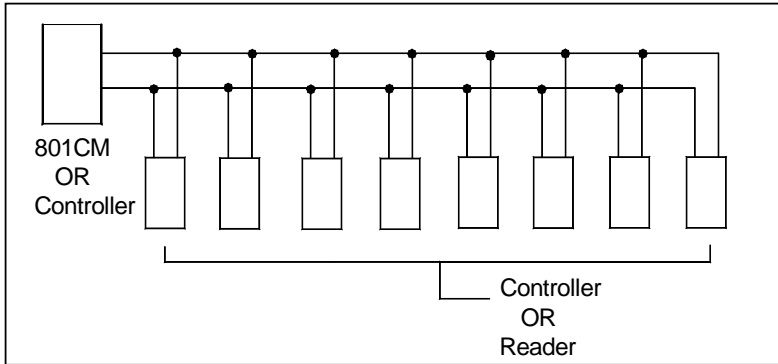

c. Don't use the following installation method, it will cause communication error.

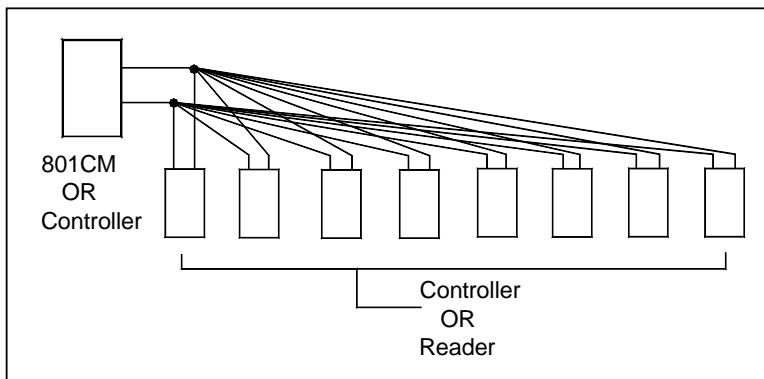

The Difference of Cables

Cable Types and Distances		
Wire Application	Cable Type	Description
From Power Supply	2-cond, 18-22 AWG	n/a
From Locking Device and power supply or gate operator	2-cond. See Mfr's Specifications	n/a
From external alarm system's Door Monitor Switch (for shunting)	2-cond, 18-22 AWG	100 m
From Exit Button	2-cond, 18-22 AWG	100 m
From Optional Auxiliary Reader	2-cond unshielded 22 AWG, plus a separate 4-cond, shielded 22-24 AWG cable	50 cm - 12 m

5. Front Panel Indicators

1. In the programming mode, if no key or card entry is made within 30 seconds, it will automatically exit the programming mode.
2. In the programming mode, LED light green and flash rapidly. It means that the controller waits for entering. LED is red and flash rapidly, it means that the reader is busy.
3. LED light green and one beep sound mean acknowledge, LED light red and two beep sounds mean not acknowledge.
4. In card learn mode, after flash card, a green light and five beeps mean that same card have existed in controller.
5. In anti-pass-back access mode, five beep sounds mean violates access function. (For AR-721H4 and AR-721H8)
6. In arming state LED light green per 0.6 second. In disarming state LED light green per 1.5 second, In alarm state LED light red per 0.4 second. (For AR-721H4 and AR-721H8)
7. If three incorrect user code (or master code) are entered, keypad will be locked for 30 seconds.
8. Press button **【0】 + 【#】** to lock/unlock keypad.
9. Press button **【*】 + 【#】** for all cards entrance allowance.
10. Press button **【#】** to function as the Bell Output.

6. Access Mode

How to program

- 2222 Duress Code (network)
- 1111 Force On/Off Code (network)
- 5678 Door Access User Code (network/standalone)
- 1234 Arming and Disarming (network/standalone)

User can select one of the following access modes

AR-721HV3 /1356

Card only

User can access the door by flashing card on the unit.

Arming / Disarming: After flashing card ok, press . Then the unit will trigger the arming/disarming mode.

Card or PWD

User can access the door by just either flash card or entering 5 digit the user number+ entering 4 digit user code +

Arming/Disarming: After flashing card ok, press . Then the unit will trigger the arming/disarming mode.

Arming/Disarming: entering 5 digit the user number+ entering 4 digit user code + , then press . Then the unit will trigger the arming/disarming mode.

Card or 4-digit User Code

User can access the door by just either flash card or entering 4 - digit user code.

Arming/Disarming: After flashing card ok, press . Then the unit will trigger the arming/disarming mode.

Arming/Disarming: entering 4 digit user code, then press . Then the unit will trigger the arming/disarming mode.

User can change user code any time

- AR-721H connects with controller and PC, running 701 client and **set user code variable.**

By user: After accessed ok, press 4-digit new user code twice and press

By 701 client \ **setting** \ **user card**

- Not connecting with PC

After accessed ok, press 4-digit new user code twice and press

Duress function

- This function could help users to send a message to the computer asking for help.
- Only available in networking state, running 701 Server and setting 4 sets of Duress code on PC. (Anyone of these 4 sets is workable.)
- This function is not available for CARD ONLY and USER CODE ONLY (AR-721H8) access.

Access Mode	Command Format
Card Only	Not available
Card + user code	Flash card, then press Duress code & #
User code Only	Not available
User no. + user code	Press user no., then Duress code & #

Note: User can access door by duress code instead of user code under card or user code access mode, but it will be shown ask for help message in 701 Client \ Daily Transaction Record.

Force on/off Code (4 sets, 4 digits)

- Only workable in networking system, running 701 Server and setting 4 sets of Force code on PC. (Anyone of these 4 sets is workable.)
- User could press related code to turn on / off its connected equipment, diagram as below.

PC board of Controller AR-716EV2 / AR-727E

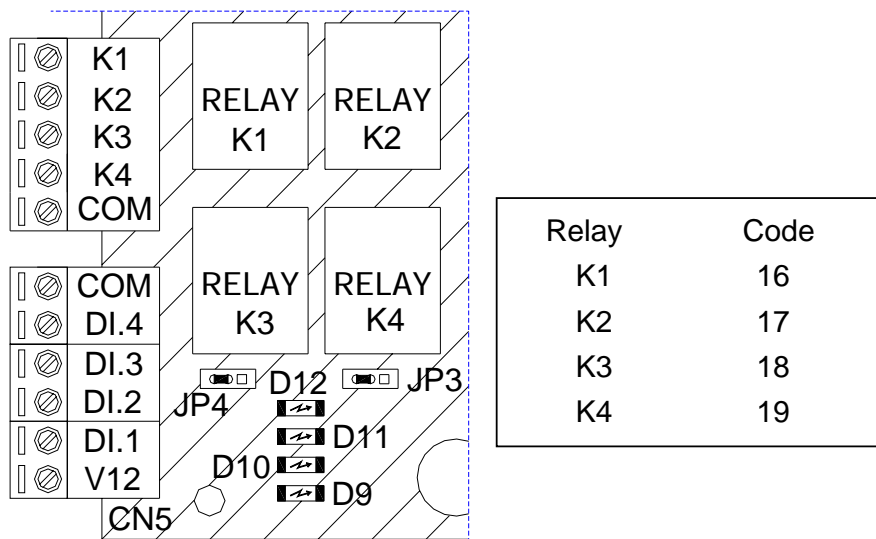

- After access OK, press following order to turn on / off its connected equipment.

Access mode	ON/Off	Order
Card only	ON	Flashing card + Force code + Code + 0 + #
	Off	Flashing card + Force code + Code + 1 + #
Card + user code	ON	Flashing card + User code + Force code + Code + 0 + #
	Off	Flashing card + User code + Force code + Code + 1 + #
User no. + user code (Mode 4)	ON	User no. + User code + Force code + Code + 0 + #
	Off	User no. + User code + Force code + Code + 1 + #
User code only (Mode 8)	ON	User code + Force code + Code + 0 + #
	Off	User code + Force code + Code + 1 + #

- This function can be connected with force control television, air conditioning, audio, etc. by Relay-1, 2, 3, 4 on the multi-door networking controller.
- To avoid the conflict of the use of each controller relay, it is user responsibility to define each controller relay for one purpose use only.

7. Function Default Value

Before installing, complete the Parameters setting by calculating each controller value according to their designated functions.

[Command 20] is used to enter [Designated Functions Setting Table] value. The default factory setting value is 016.

7.1 For AR-721HV3/ 1356

Designated Functions Setting Table					
Functions	Optional		Bit	Value	Remark
Recording every entry/exit on Time Attendance Report	0:YES *	1:NO	0	001	network
Auto Re-Lock	0:disable *	1:enable	1	002	
Auto Open/Auto Disarming	0:disable*	1:enable	2	004	network
Door Exit Release (Push Button)	0:disable	1:enable*	4	016	
Master Reader /Network	0:minor*	1:major	5	032	network
Entry / Exit door	0:exit door*	1:entry door	6	064	
Anti-pass-back door	0:disable *	1:enable	7	128	

Listed above with [*] markings are the factory setting. Multiply the optional functions number [1] by its value and add them up. Note that AR-721H7 has no Anti-pass-back door function.

7.2 For AR-721H6

Designated Functions Setting Table					
Functions	Optional		Bit	Value	Remark
Auto Re-Lock	0:disable *	1:enable	1	002	
Door Exit Release	0:disable	1:enable*	4	016	

8. Wiring

Table 1 - Connector P1 Color Coding			
Wire Application	Wire	Color	Description
Door Relay	1	Blue White	(N.O.)DC24V1Amp
	2	Purple White	(N.C.)DC24V1Amp
	3	White	(COM)DC24V1Amp
Door Sensor	4	Orange	Negative Trigger Input
Exit Switch	5	Purple	Negative Trigger Input
Alarm Output	6	Grey	Transistor Output (Open Collector Active Low)
Power	7	Thick Red	DC Power 12V
	8	Thick Black	DC Power 0V

Table 2 - Connector P2 Color Coding (Wiegand Read Head)			
Wire Application	Wire	Color	Description
Wiegand	1	Thin Blue	Wiegand DAT:1 Input
	2	Thin Green	Wiegand DAT:0 Input
Beeper	3	Pink	Beeper Output 5V/100mA, Low
LED	4	Brown	LED Green Output 5V/20mA, Max
	5	Yellow	LED Red Output 5V/20mA, Max

Table 3 - Connector P3 Color Coding (Tamper Switch)			
Wire Application	Wire	Color	Description
Tamper Switch	1	Red	N.C.
	2	Orange	COM
	3	Yellow	N.O.

Table 4 - Connector P4 Color Coding			
Wire Application	Wire	Color	Description
Networking Module	1	Thick Green	RS-485(B-)
	2	Thick Blue	RS-485(A+)

9. Installation diagram

9.1 Magnetic lock

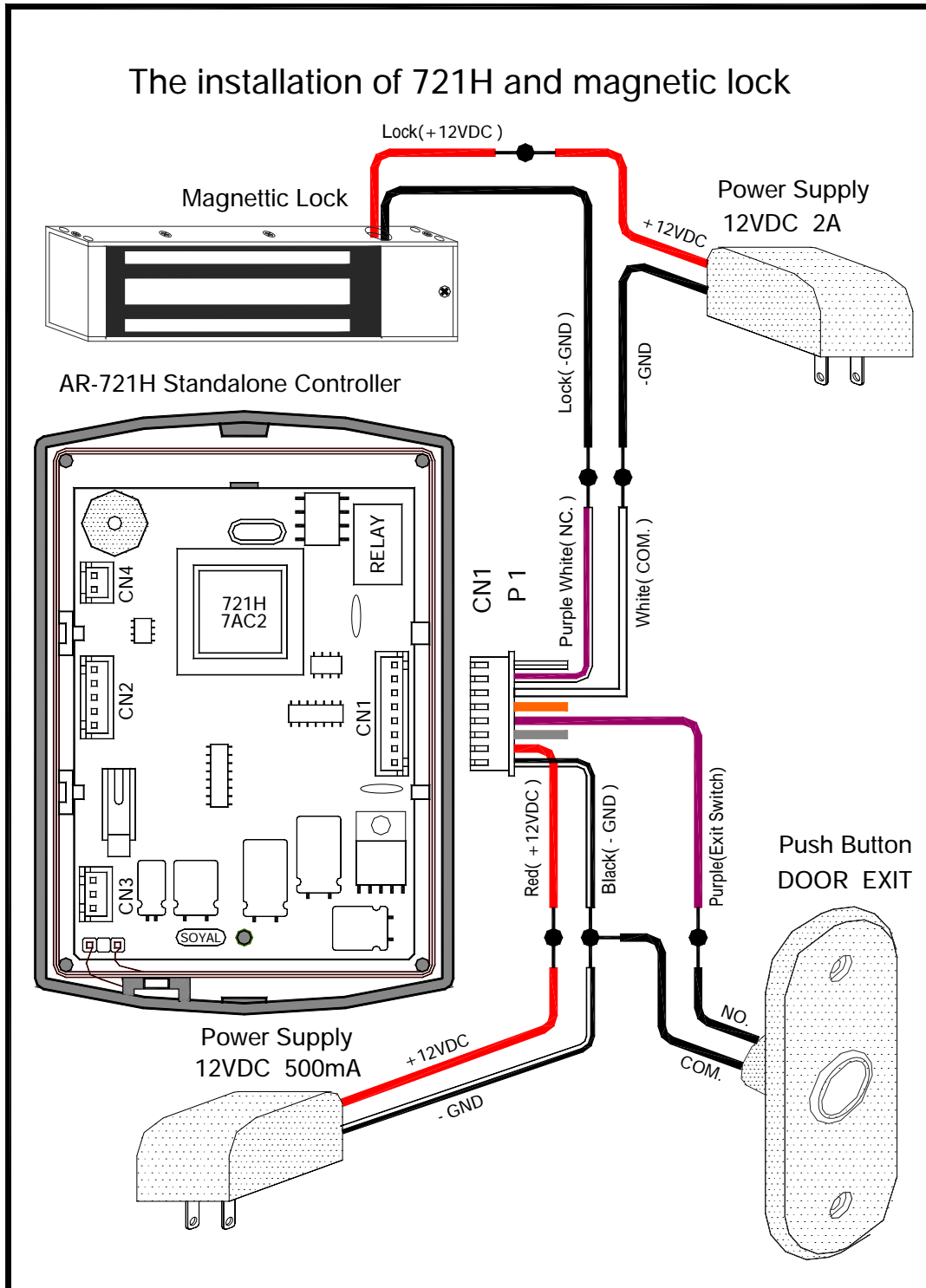

9.2 Electric bolt lock

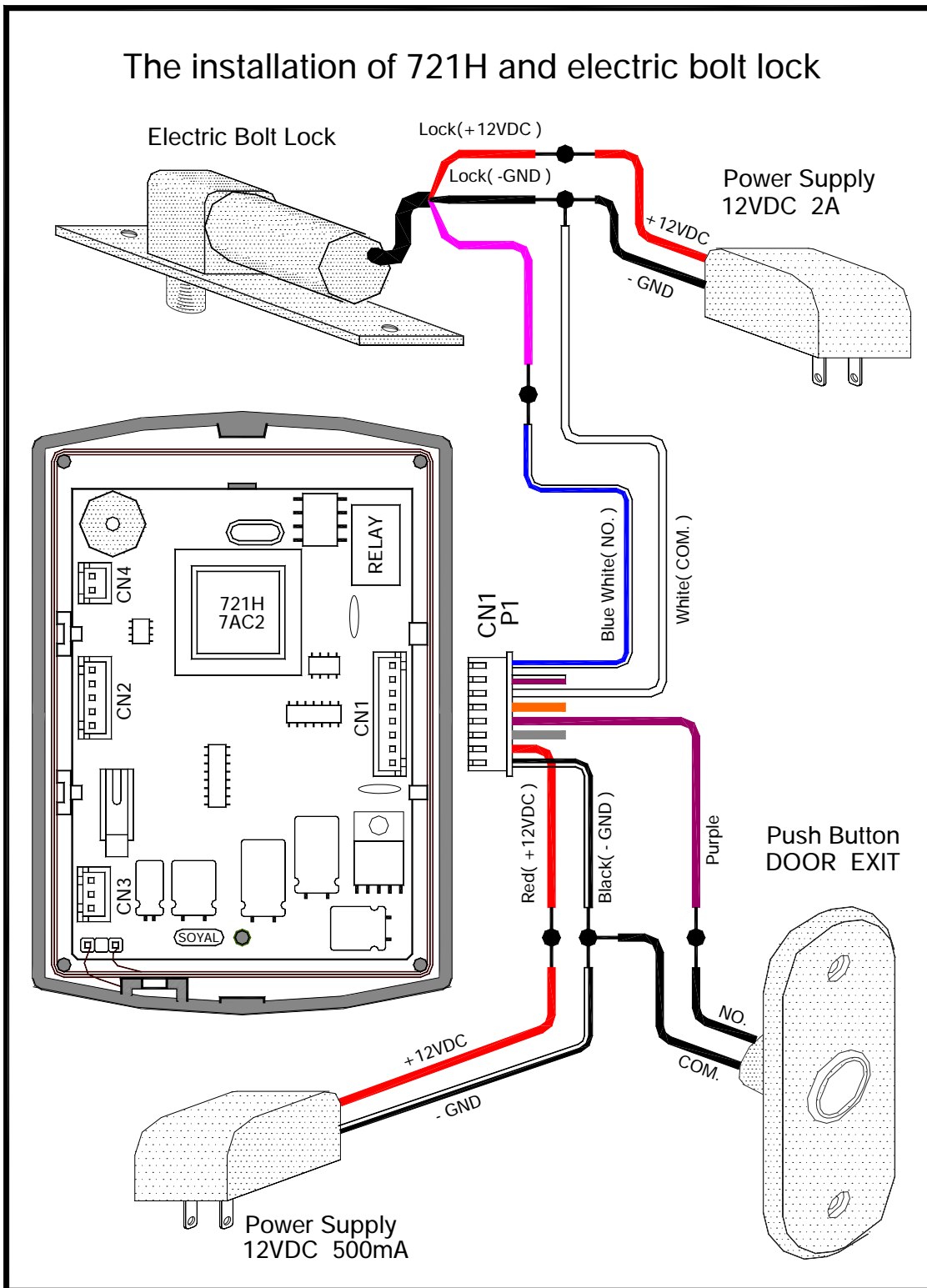

9.3 Electric strike

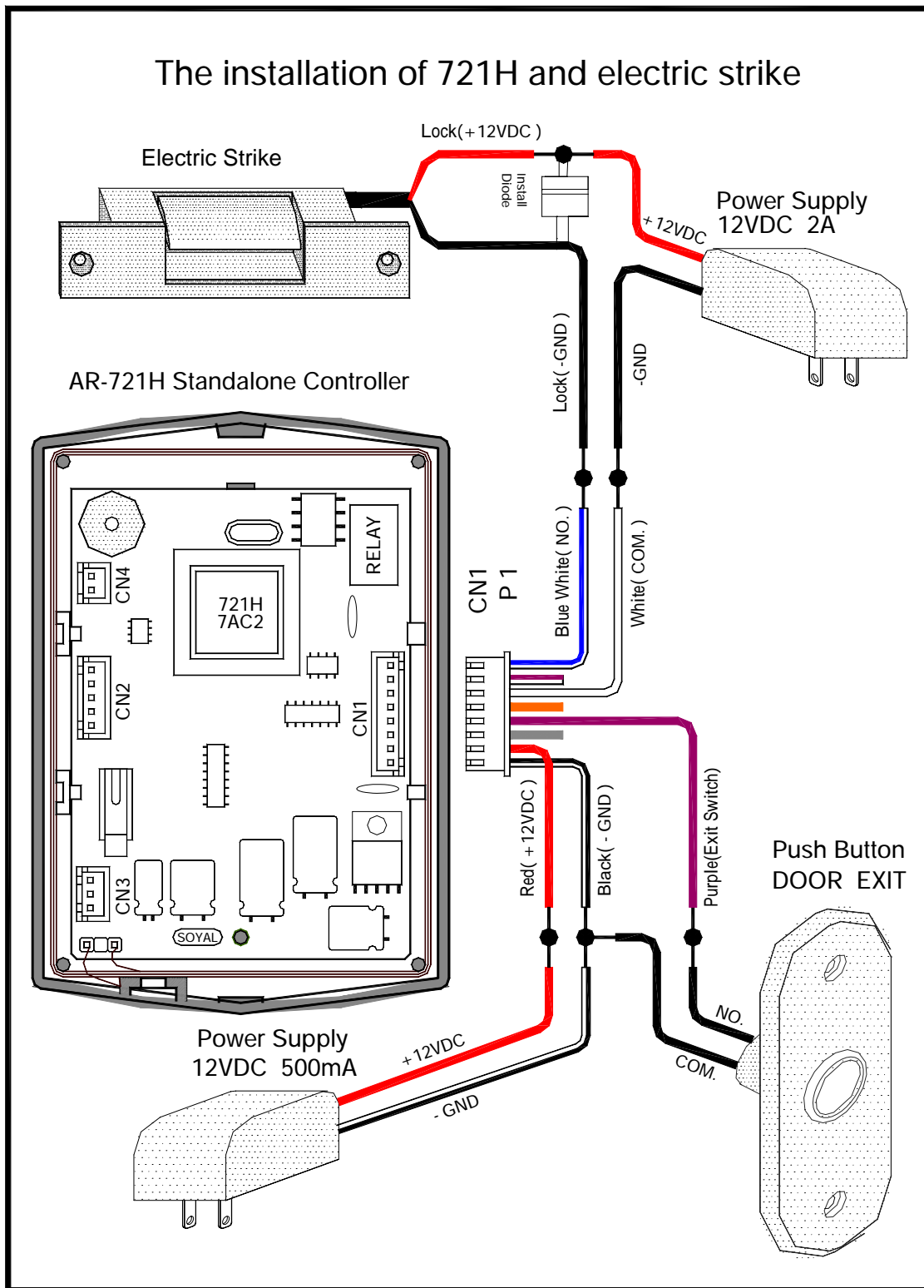

9.4 Magnetic door contacts and alarm system

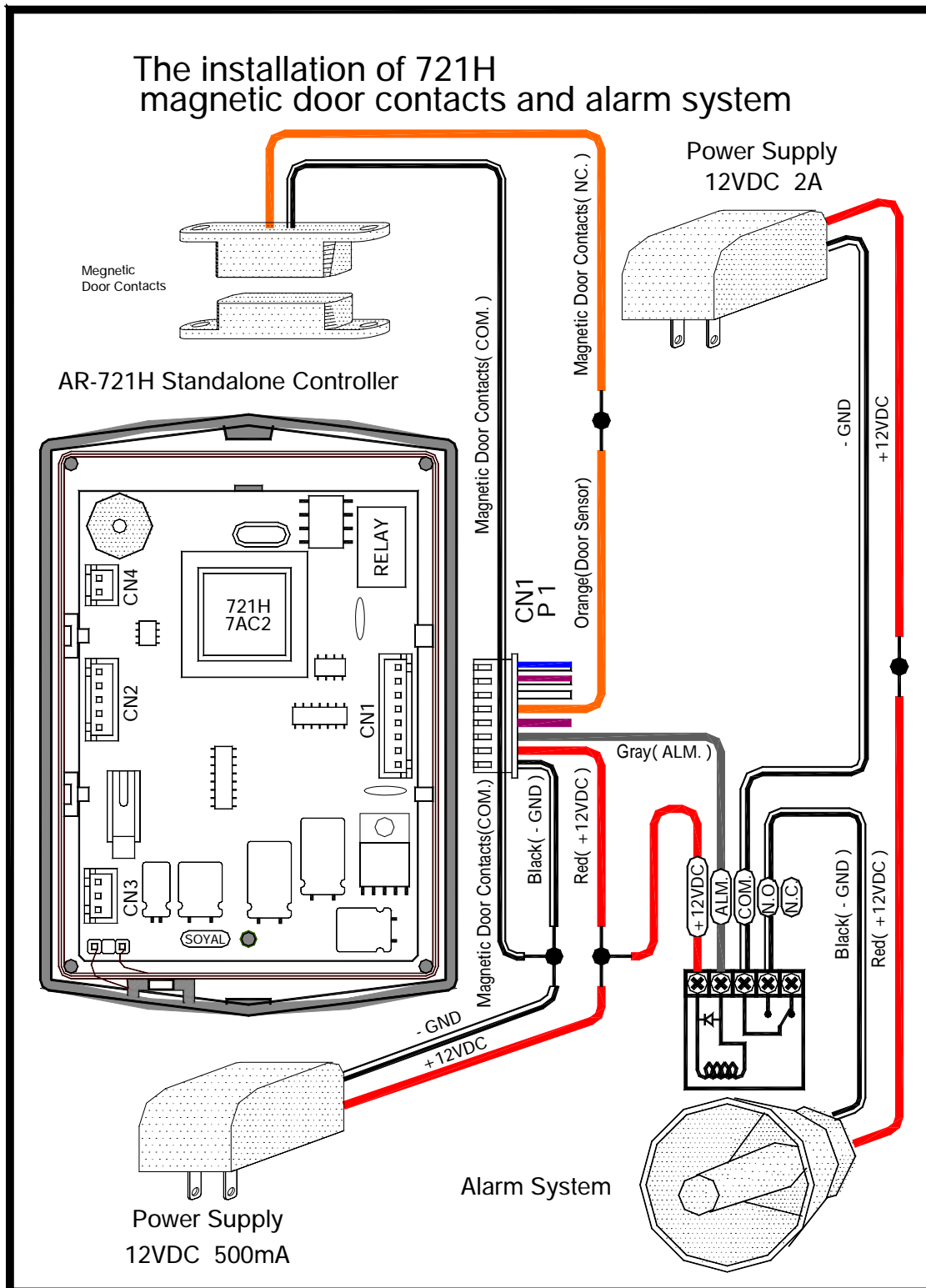

9.5 Wiegand reader

9.5.1 AR-721U

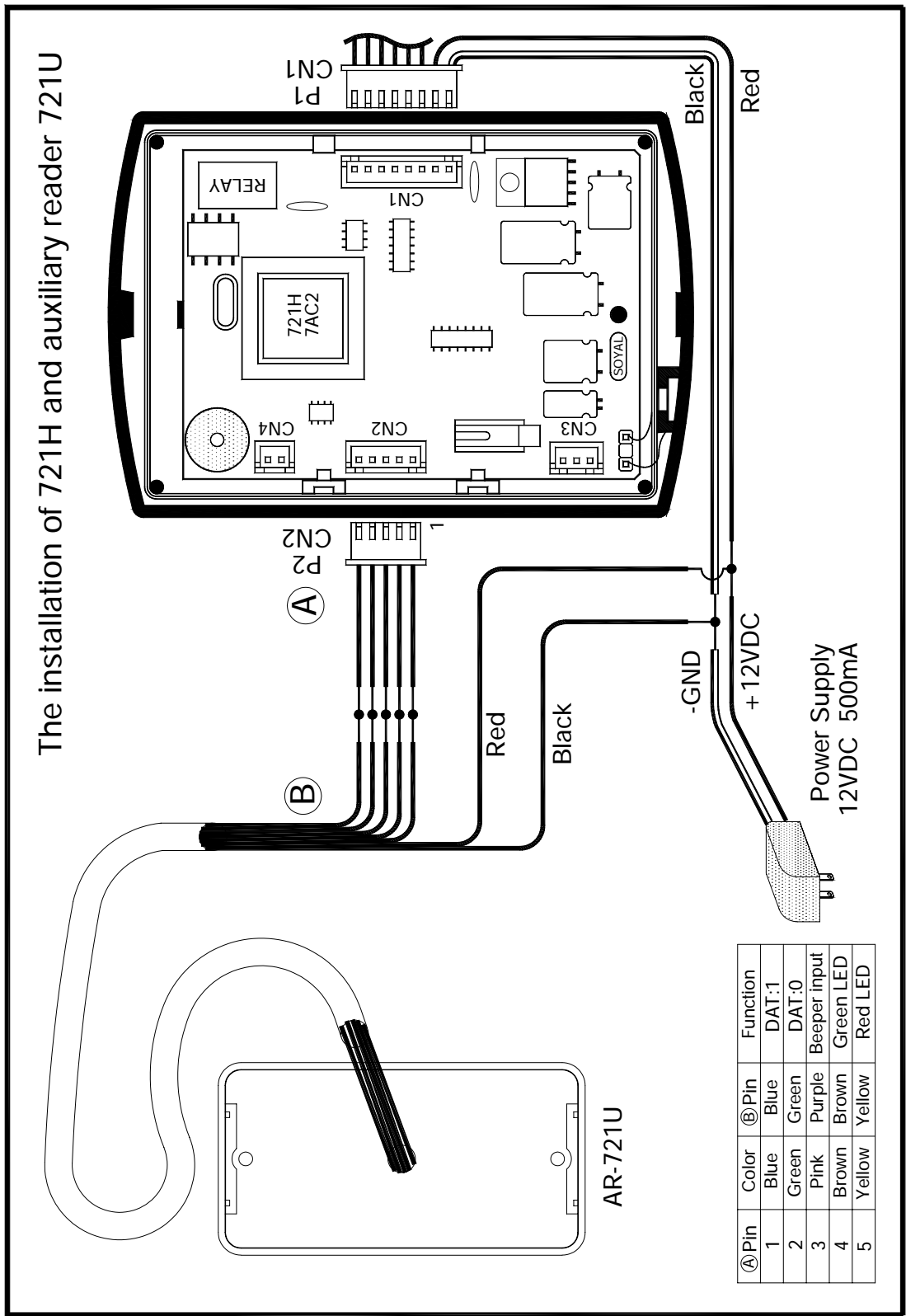

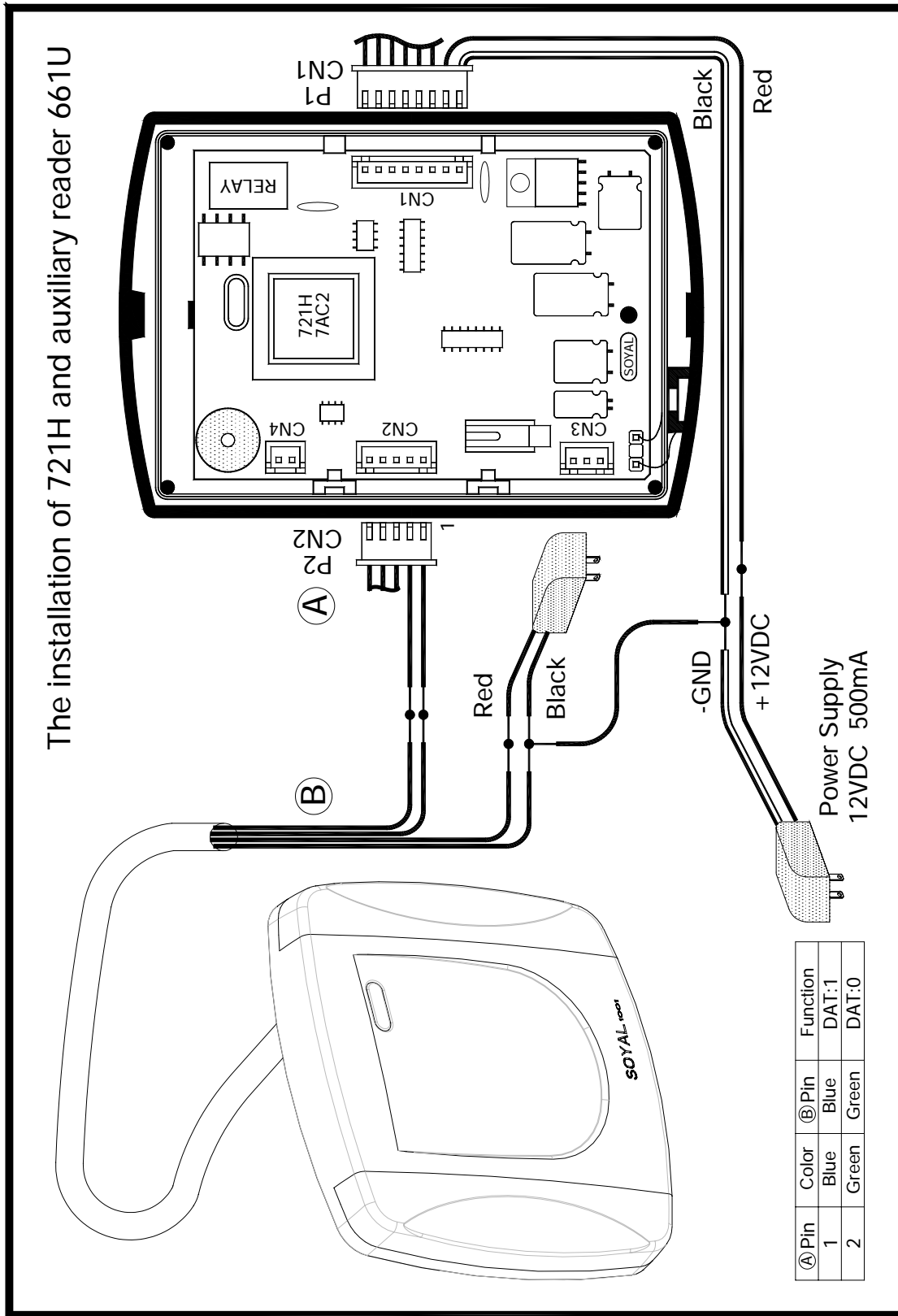

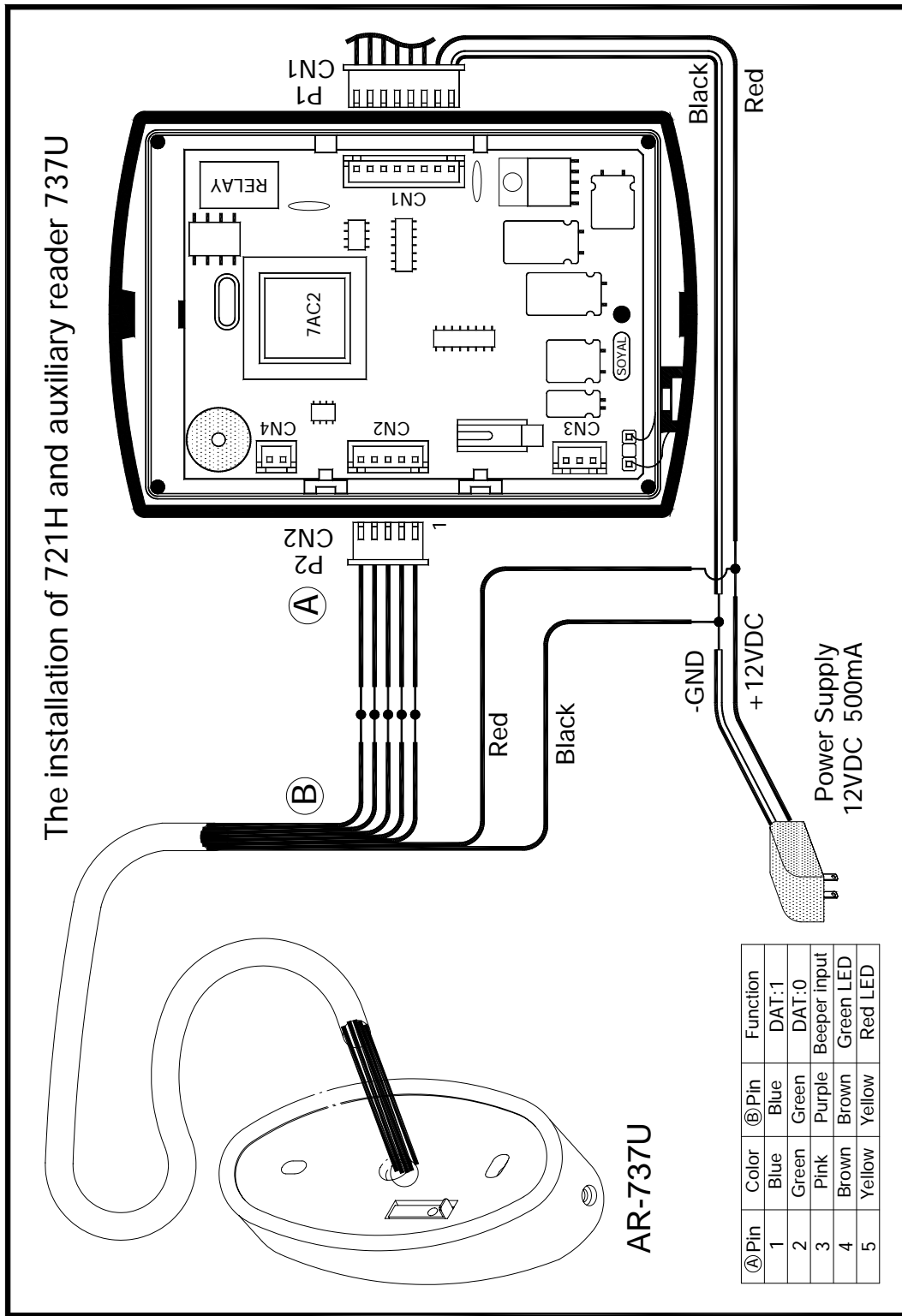

9.6 Networking installation

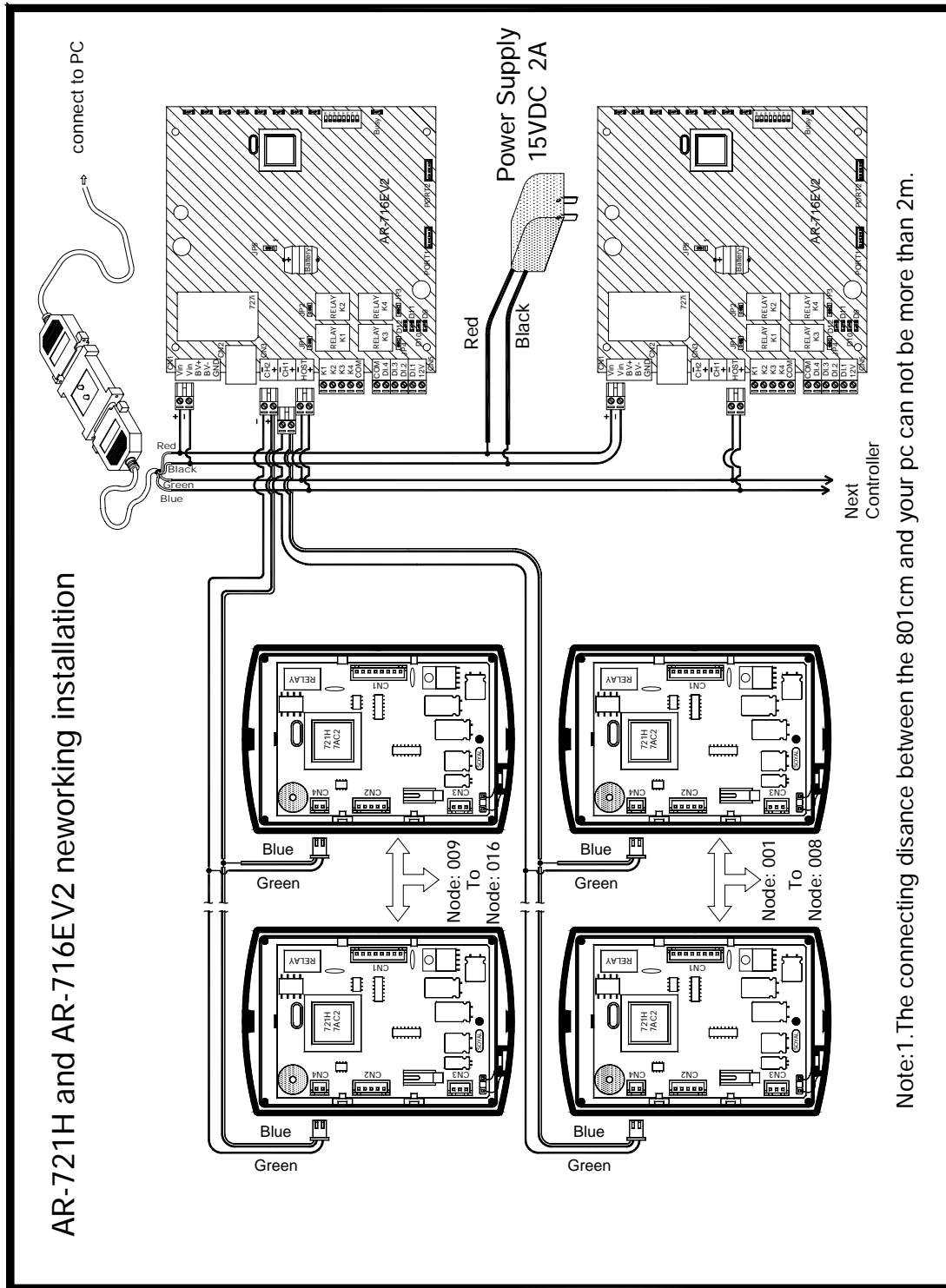

9.7 Lift controller

9.7.1 AR-721R32 installation

The installation of 721H7 and elevator controller 721R32

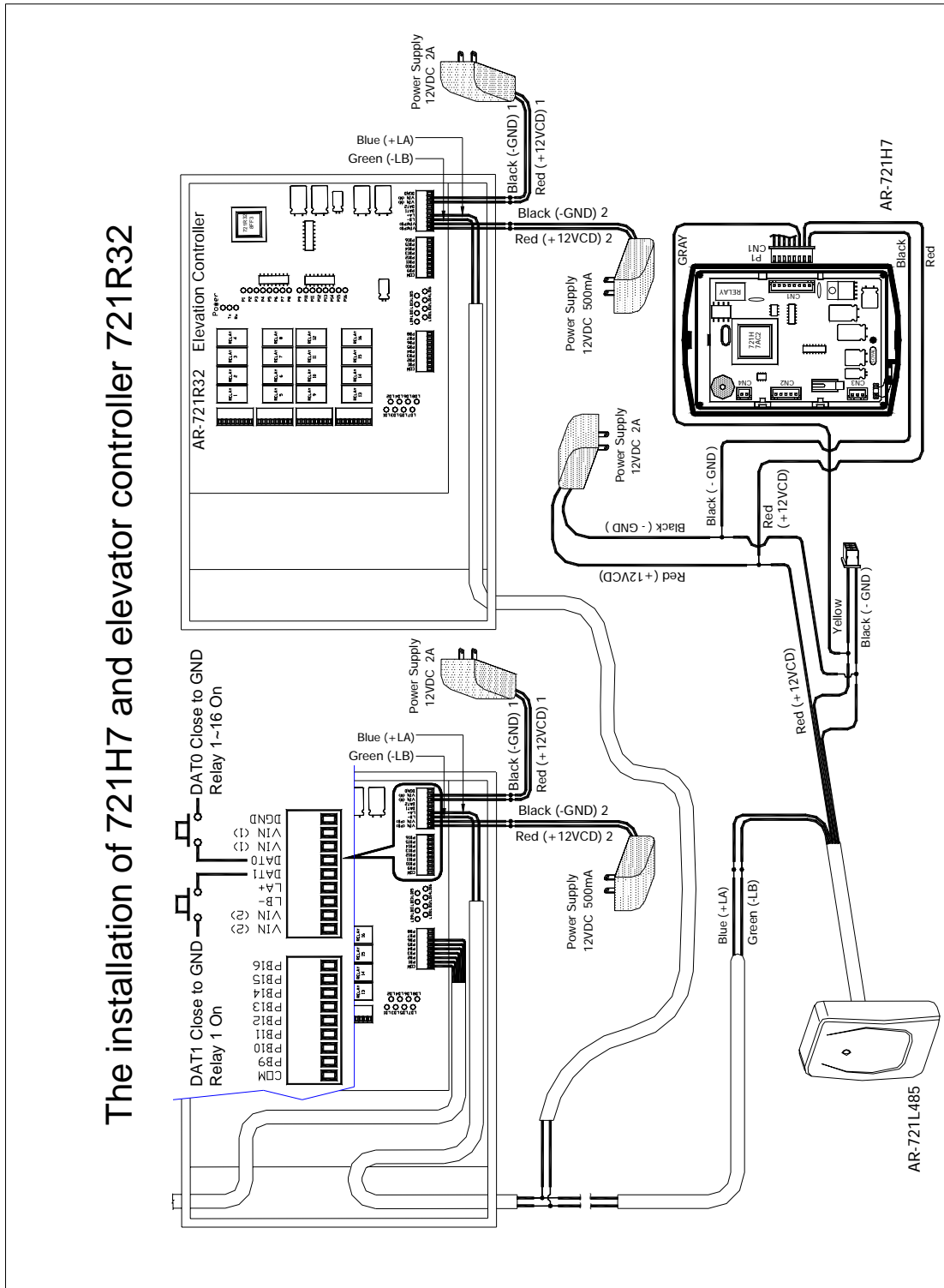

9.7.2 AR-401RO16 installation

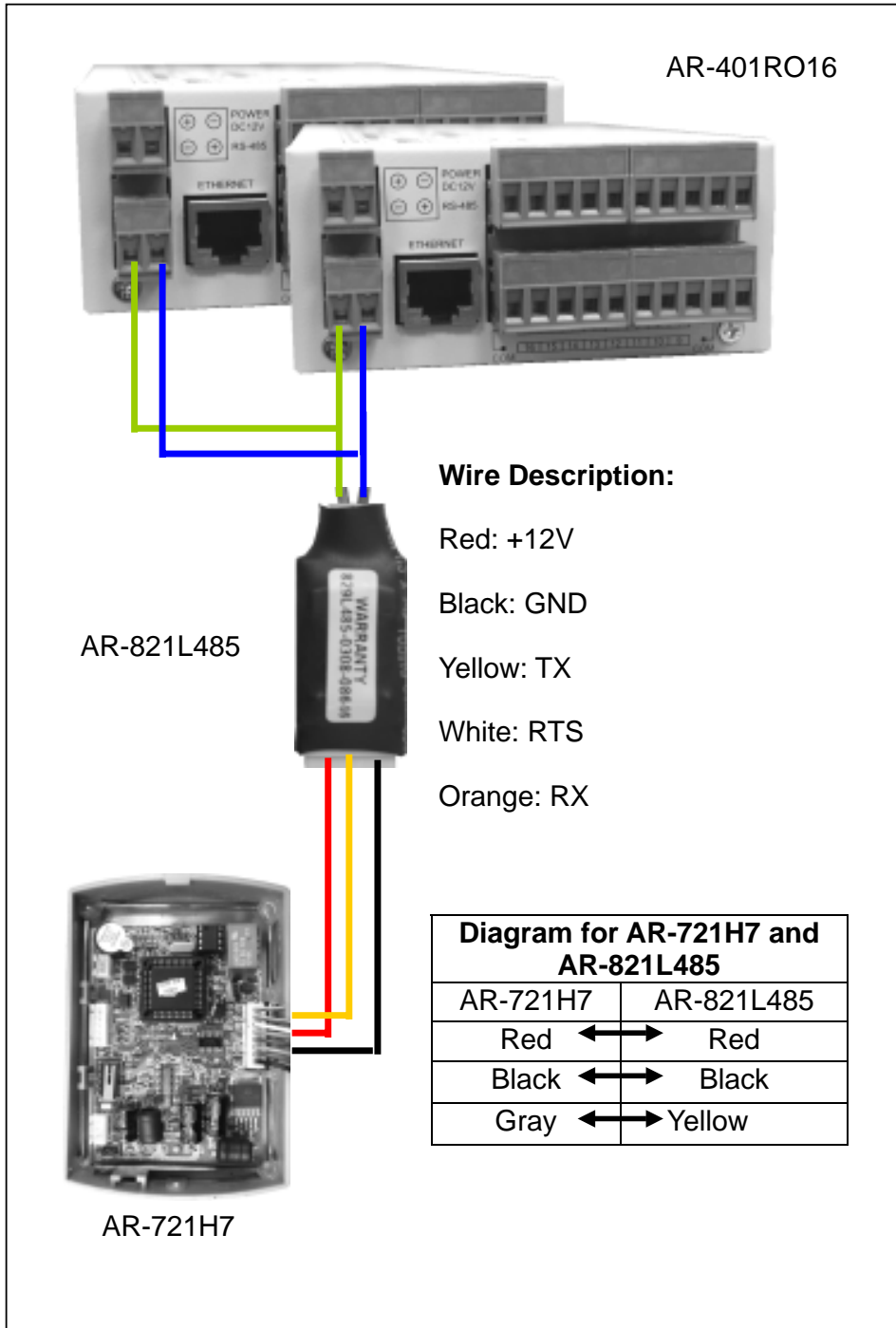

10. Installation

INSTRUCTIONS:

1. Use the screwdriver to screw the mounting plate on the wall.
2. Pull cable ends through the access hole in the mounting plate.
Connect plug P1 to socket CN1 on the AR-721H circuit board.
Connect plug P2 to socket CN2 on the AR-721H circuit board.
Connect plug P3 to socket CN3 on the AR-721H circuit board.
Connect plug P4 to socket CN4 on the AR-721H circuit board.
3. Attach the AR-721H to the mounting plate and install screw (supplied) into the hole at the bottom with the Allen wrench (supplied).
4. Apply power. The red LED will flash once and the beeper will sound.

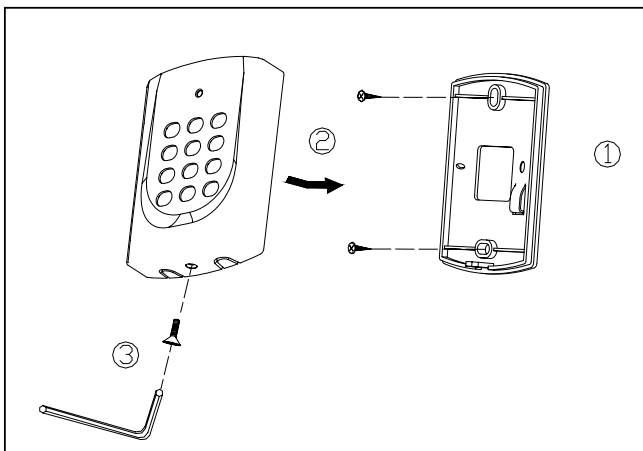

11. Troubleshooting

Questions	Answer
No appearance	<ol style="list-style-type: none">1. Check power, if it is 9 – 24 VDC adaptor?2. Check if the polarity is correct?3. The unit should make a beep sound when any key on the keypad is depressed.4. If you remove and restore power, the unit should beep once and the LED should flash red once.

12. Return of Products

If you think that you have a defective unit, please contact the distributor who sold you the unit. All service and repairs must be done through an authorized distributor.

13. Warranty

SOYAL warrants that the product(s) shall be free from manufacturing defects in materials and workmanship for a period of fifteen (15) month from the date of delivery provided that the product was properly installed and used. The foregoing warranty shall not apply to defects resulting from abuse, misuse, accident, unauthorized alteration or repair, neglect, acts of God (such as floods, fire, etc.). SOYAL shall, at its option, either repair or replace product(s) which prove to be defective within the warranty period. SOYAL will replace any product found to be defective within the first three months of purchase provided said product was properly installed and used. Distributor agrees to insure the product or assume the risk of loss or damage in transit to prepay shipping charges and to use the original shipping container or equivalent. Customers shall seek assistance from the distributor who sold you product(s). Repaired or replaced product(s) are warranted for ninety (90) days from the date of repair or replacement, or for the remainder of the original product's warranty period, whichever is longer.

Note: Don't tear a paster such as S/N: 721H4-08336 on the PCB board, because it is SOYAL warranty.

Removable CPU

The CPU of this generation version of AR-721H series can be removable. If the master code is forgotten it can be restored to the factory default (123456). Remove the AR-721H series from the mounting plate, disconnect power, remove AR-721H CPU, install AR-721H-CLE CPU, and restore power about 10 seconds. Then disconnect power, remove AR-721H-LCE CPU, install AR-721H CPU, and restore power.

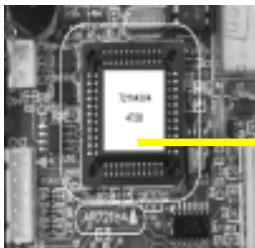

- 1) If CPU at hand as above stand for The CPU of first generation version of AR-721H series. You can refer the above step to restore master code to the factory default (123456).
- 2) You can know item no. and CPU version of the device from CPU paster of left picture. So, this device is AR-721H4, CPU version 3V4 and checksum 472B

14. Mode 4 Easy Guide

Either way to enter the programming mode

1. Press + +
(all new units are preprogrammed with the master code 123456)
2. Flash master card and then press within 2 seconds.
The LED will flash green rapidly to show that the unit is in the programming mode.
The unit will time out and return to the reading mode in 30 seconds if no key is pressed.

Either way can exit the programming mode

1. Press -- exit the programming mode and return to the reading mode.
2. Press -- exit the programming mode, set controller to arming state and return to the reading mode.

Change your Master Code

Step1: Press and master code follow an

Step2: Enter

Re-type New Master Code-654321

A green light and beep means that the master code was changed. Note that 123456 is the default master code; use another number for best security.

Step3: Press

Set the door relay release time

Step1: Press and master code follow an

Step2: Enter

7 Seconds

TTT = 000: Latch (Trigger) / TTT = 001 ~ 600 (001 ~ 600)

seconds / TTT = 601 ~ 609 (0.1 ~ 0.9) second. A green

light and beep means that the door relay release time was changed.

Step3: Press

Add one Transponder (Card / Key Tag) to the system

Step1: Press and master code follow an

Step2: Enter

User Number

Quantity

Present the transponder near the unit. (Set random transponder one by one). A green light and beep means that the transponder was accepted.

Step3: Press

Add a series of Transponders (Card / Key Tag) to the system

Step1: Press and master code follow an

Step2: Enter

User Number

Quantity

Present the lowest card code of transponder to the unit in the desired order (set sequential transponder once and make a careful record of which transponders are assigned to which user numbers).

Step3: Press

Add a User Code to the system

Step1: Press and master code follow an

Step2: Enter

User Number

User Code

The user number 00001 can access the door by just either flash card or entering the user number 00001, then entering 2081#.

OR Enter

User Number

User Code

The user number 00001 can access the door by using flash card and entering 2081#.

Note: A user code must be 4 digits. If the user code has leading zeros, they must be entered as this example show "0008".

Step3: Press

Delete a Transponder / User Code from the system

Step1: Press and master code follow an

Step2: Enter

Starting User Number 1

Ending User Number 1

A green light and beep means that the transponder / user code was deleted.

Step3: Press

Delete a range of Transponders / User Code from the system

Step1: Press and master code follow an

Step2: Enter

Starting User Number 1

Ending User Number 10

A green light and beep means that the range of transponders / user codes were deleted.

Step3: Press

Delete all Transponders

Step1: Press and master code follow an

Step2: Enter

The LED flash red during 10 seconds to mean that the system is deleting all transponders / user codes. Then a green light and beep means that all transponder / user codes were deleted.

Step3: Press

Enable a Transponder to the system

Step1: Press and master code follow an

Step2: Enter

Starting User Number 1

Ending User Number 1

A green light and beep means that the transponder is enabled.

Step3: Press

Enable a range of Transponder to the system

Step1: Press and master code follow an

Step2: Enter

Starting User Number 1

Ending User Number 10

A green light and beep means that the range of transponders are enabled.

Step3: Press

15. Mode 8 Easy Guide

Add one Transponder (Card / Key Tag) to the system

Step1: Press and master code follow an

Step2: Enter

User Number

Quantity

Present the transponder near the unit. (Set random transponder one by one).

A green light and beep means that the transponder was accepted.

Step3: Press

Add a User Code to the system

Step1: Press and master code follow an

Step2: Enter

User Number

User Code

The user number 00001 can access the door by just either flash card or entering 2081.

OR Enter

User Number

User Code

The user number 00001 can access the door by using flash card and entering 2081#.

Note: A user code must be 4 digits. If the user code has leading zeros, they must be entered as this example show "0008".

Step3: Press

Other operation is same as AR-721H4 Easy Guide, for example, enter/ exit the programming mode, change master code, door relay release time, add / delete / enable one or many transponder and so on.

16. Mode 6 Easy Guide

Enter the programming mode

Press + +

(all new units are preprogrammed with the master code 123456)

The LED will flash green rapidly to show that the unit is in the programming mode. The unit will time out and return to the reading mode in 30 seconds if no key is pressed.

Add one Transponder (Card / Key Tag) to the system

Step1: Press and master code follow an

Step2: Enter

Starting Card Code

Ending Card Code

A green light and beep means that the transponder was accepted.

Step3: Press

Add a series of Transponders (Card / Key Tag) to the system

Step1: Press and master code follow an

Step2: Enter

Starting Card Code

Ending Card Code

Set sequential transponder once and make a careful record. A green light and beep means that the transponder was accepted.

Step3: Press

Add the common Code to the system

Step1: Press and master code follow an

Step2: Enter

Common Code

All users can access the door **by only entering common code (Default value: 4321)** on the unit.

OR Enter

Common Code

This function is disable. All users cannot access the door by only entering common code.

OR Enter

Common Code

All users can access the door **by flashing card and entering common code (Default value: 1234)** on the unit.

OR Enter

User can access the door by flashing card on the unit.

Step3: Press

Set system clock times

Step1: Press and master code follow an

(all new units are preprogrammed with the master code 123456)

Step2: Enter

YY: Year MM: Month DD: Date HH: Hour mm: Minute SS: Second

(Ex. 000125 = 25th January, 2000)

(Ex. 235901 = 23:59:01 PM)

Step3: Press

Other operation is same as AR-721H4 Easy Guide, for example, exit the programming mode, change master code, door relay release time, delete one or many transponder and so on.

17. Mode 7 Easy Guide

To exit the programming mode

Press -- exit the programming mode and return to the reading mode.

Set a user number arrive one floor

Step1: Press and master code follow an

Step2: Enter

User Number

Access 31st floor

A green light and beep means that the setting was accepted.

Step3: Press

Set a user number arrive many floor

Step1: Press and master code follow an

Step2: Enter

User Number

Group Access 8th, 7th, 2nd, and 1st floors

Group	Floor address							
0	8	7	6	5	4	3	2	1
1	16	15	14	13	12	11	10	9
2	24	23	22	21	20	19	18	17
3	32	31	30	29	28	27	26	25

A green light and beep means that the setting was accepted.

Step3: Press

Set a AR-721R32 node address (AR-401RO16 don't need to set this command. It is set by DIP switch on the device)

Step1: Press and master code follow an

Step2: Enter

AR-721R32 node address

A green light and beep means that the setting was accepted.

Step3: Press

Set the Relay time for push button and present card input of an elevator controller

Step1: Press and master code follow an

Step2: Enter

AR-721R32 node address

Pushbutton input Present card input

A green light and beep means that the setting was accepted.

Step3: Press

Note: AR-401RO16 has no push button input function, but you still enter push button input second in order to complete this command. Otherwise, this command will be failed).

Other operation is same as AR-721H4 Easy Guide, for example, enter the programming mode, change master code, door relay release time, add / delete / enable one or many transponder and so on.

18. Special Design

18.1 How to set anti-pass-back?

Card and on-line reader (or standalone controller) must be both set anti-pass-back.

- Set card to have anti-pass back checking

Step1: Press and master code follow an

(all new units are preprogrammed with the master code 123456)

Step2: Enter

SSSSS: Starting User Number

EEEE: Ending User Number

X: 1 - disable anti-pass-back

0 - enable anti-pass-back

2 - Initiating use (when user number violates anti-pass-back, the user number can access either entry door or exit door by initiating setting)

Step3: Press

For example:

If enter 26*00005*00008*1#, user number from 5 ~ 8 do not have anti-pass-back feature.

If enter 26*00005*00008*0# or 26*00005*00008*2#, user number from 5 ~ 8 have anti-pass-back feature.

- Set on-line reader's (or standalone controller) anti-pass-back function

CASE 1: AR-721H do anti-pass-back with its auxiliary reader (AR-721U, AR-721K or AR-661U)

Step1: Press and master code follow an

Step2: Enter

Step3: Press

CASE 2: AR-721H do anti-pass-back with 2 pcs of AR-661U long-range reader (Set one AR-661U being Exit reader and the other one being Entry reader). This special design is especially suitable for car parking control. CPU version is at least 3.1V. Set one AR-661U with wiegand 34 bit format output and the other one with 38 bit. (Please refer to the following diagram)

Step1: Press and master code follow an

Step2: Enter

Step3: Press

AR-721H do anti-pass-back with 2 pcs of AR-661U

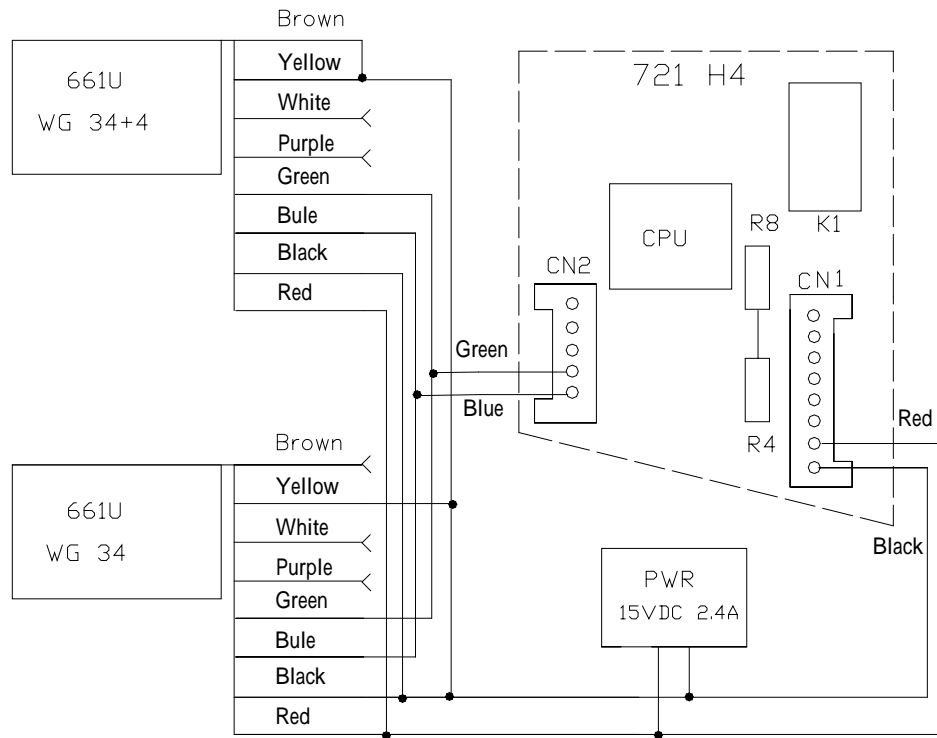

	Output		Selection	
Output	WG26	WG34	RS-232	WG34+4
SEL1	Open	Close to GND	Open	Close to GND
SEL2	Open	Open	Close to GND	Close to GND

AR-661U Circuit Manual

Red: +12V Purple: Buzzer Output
 Black: GND Yellow: SEL1
 Blue: WG_D1 Brown: SEL2
 Green: WG_D0
 White: Gard Present

When the distance between 2 pcs 661U is less than 6 meter (suggestion value), we can use the following ways to solve in order to avoid interference with each other to result in reading distance decrease.

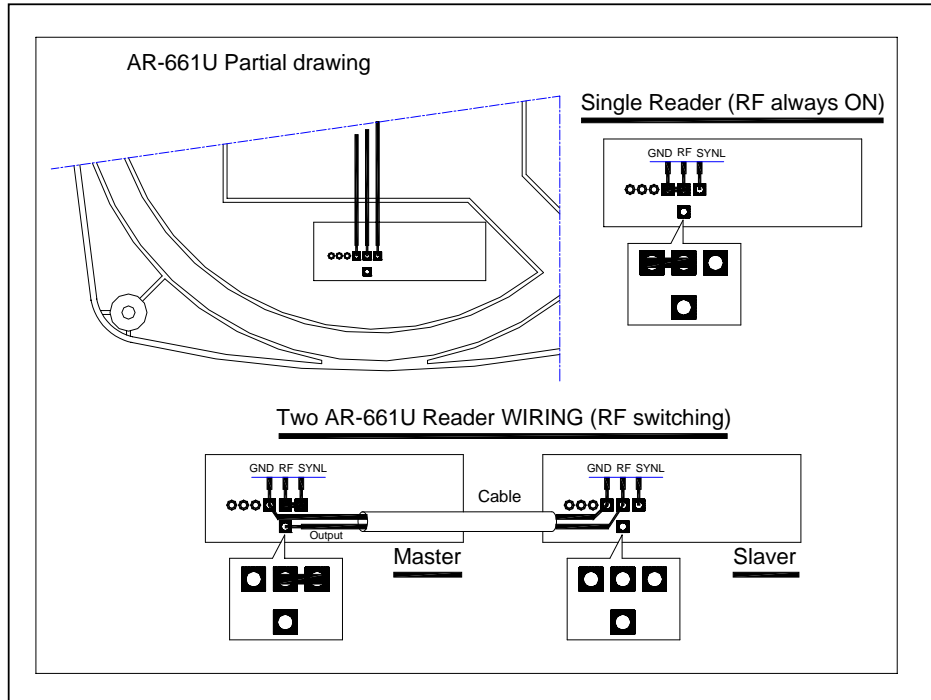

CASE 3: On-line reader under AR-716Ei / EV2 networking controller

do anti-pass-back each other. You need to indicate which is entry door and which is exit door in advance. Note that on-line reader under A networking controller cannot do anti-pass-back with on-line reader under B or C networking controller, contrariwise.

Entry door

- Step1: Press and master code follow an
- Step2: Enter
- $192=128(\text{Anti-pass-back door})+64(\text{Entry door})$
- Step3: Press

Exit door

- Step1: Press and master code follow an
- Step2: Enter
- $128=128(\text{Anti-pass-back door})+0(\text{Exit door})$
- Step3: Press

19. Transponder Record Table

19.1 For AR-721H4, AR-721H7 and AR-721H8

Be sure to record the user number, the user name, the card ID number (site code: card code), and the user code and keep this information in a secure place. A black user log form has been included for purpose. Do not write on this form; use it as a photocopy master.

User no.	User Name	Site code: Card code	User code

Function	Command	Programmed Values
Master code	09*PPPPPPCCCCC#	123456
Door relay release time	02*TTT#	003 (3 seconds)
Function code (Arm or Disarm)	17*PPPP#	1234 (not including AR-721H7)

19.2 For AR-721H6

Be sure to record the user number, the user name, the card ID number (card code), and the user code and keep this information in a secure place. A black user log form has been included for purpose. Do not write on this form; use it as a photocopy master.

User no.	User Name	Card code	User code

Function	Command	Programmed Values
Master code	09*PPPPPPCCCCC#	123456
Door relay release time	02*TTT#	003 (3 seconds)
Common code (1)	15*PPPP#	4321
Common code (2)	17*PPPP#	1234

20. F.A.Q.

Q : How to input Duress Code in your SOYAL reader?

Step1. Setting the Duress :

Press button into Editing mode.

When in editing mode, enter

You can enter 4 numbers to be as Duress Code.

Step2. Start the operation :

Press 4 numbers of Duress Code and flashing card.

The Duress will be switched up !

Q : How to configure alarm relay time when the door open too long?

Before this procedure, you have to configure the function "ALARM RELAY TM" , "DOOR CLOSE TM" , and "FORCE OPEN".

Step1. In editing mode, press and enter the time for alarm relay time setting.

Step2. In edit mode, press and enter the time for alarm triggered setting.

Step3. In edit mode, press and enter 3 numbers.

Close Force-Open order: press

Function Force-Open order :press

Press to quit the edit mode and keep arming.

Q : How to set the function “open two door”in your reader ?

First of all, you must make sure that you have the Wiegand Reader used with AR-721HV3 series in this function.

Press --Open two doors.

This function is good for using together with auxiliary reader. AR-721 HV3 and auxiliary reader open different door. Note that this function cannot use with Arming function at the same time.

Q : How to delete all Transponders in your SOYAL reader ?

In edit mode, press then the data will be erased in your system.

Press to exit this setting module !!

Q : How to set the door relay release time?

When in edit mode,

Press Time range is 000~600 sec.

Press the button below, ~

It's mean 000~600 seconds for door relay time.

Press the button below, Latch/Toggle mode will be functioned.

The door will remain open by flashing card in one time.

The door will remain close by flashing card in one time.

Press the button below, ~

It's mean 0.1~ 0.9 seconds for door relay time.

A green light and beep means the door relay release time was changed.

Q : How to function the Arming & Disarming?

Press to set 4-digit function code.
Function code followed with to Arm or Disarm the system.

Default setting : is 1234.

Q : How to add Transponder (Card / Key tag) to the system ?

In edit mode, please press the buttons as below:

Q : How to set Door-bell system ?

Alarm output used with Relay is the formal type of this function.

When you in edit mode , press

The Door-bell system will function.

Q : How to set Free access Mode ?

1. Standalone:

In edit mode, please Press +

2. Networking: connecting with AR-716E

In edit mode, please Press +

Note:

This function not allowed the reader in standalone when connect to controller.